

## Handling Components

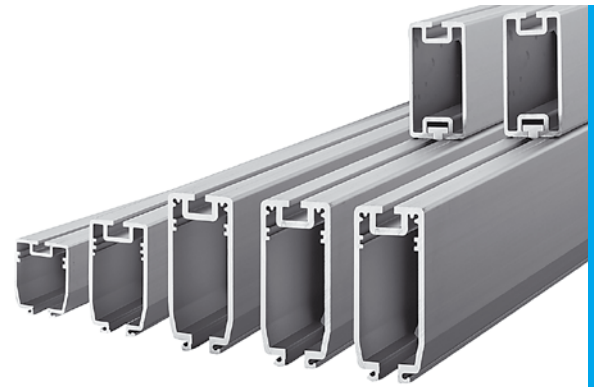

## Light weight overhead rail system - Movorail

- Low weight means easy to handle and install
- Five basic sizes
- Can handle loads up to 600 kg
- Anodised aluminium profiles
- Quick installation
- Modular design
- Easy to install suspensions
- No welding required at installation
- Large number of trollies for different requirements available
- Broad range of options available



**PAGE 6**

## High speed overhead rodless actuators - Tollobelt

- Light weight belt driven unit in four sizes
- Extruded aluminium profile
- Easy to install
- Speed up to 5 m/s
- Stroke up to 20 m
- Load up to 600 kg
- Up to four trollies per unit possible
- Suitable gear boxes available
- Units can be synchronized using intermediate shafts



**PAGE 11**

## Industrial lifting actuators - MovoZ

- Telescopic space saving lifting units
- Ball screw drive with safety nut
- Slide guides
- Stroke up to 1,5 m
- Speed up to 1 m/s
- Load up to 7500 N
- Repeatability down to  $\pm 0,1$  mm
- Mounting frames available
- Suitable worm gears and belt gears available



**PAGE 17**

## Lifting units - Movolift

- Lifting units based on MovoZ Z3
- Ready for suspension in Movorail or Tollobelt systems
- Easy to install
- Ball screw drive with safety nut
- Comes with motor, gear box, limit switches and mounting frame
- Frame with manual or motorized rotation available
- Stroke up to 1,5 m
- Lifting speed up to 0,4 m/s
- Load up to 7500 N



**PAGE 23**

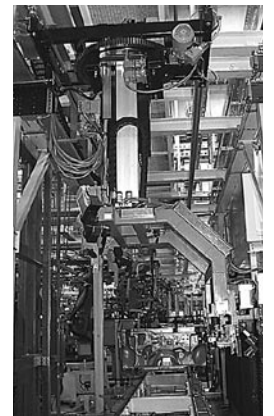
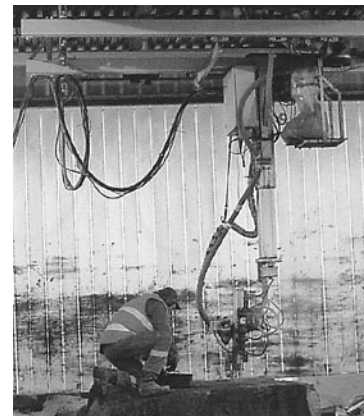
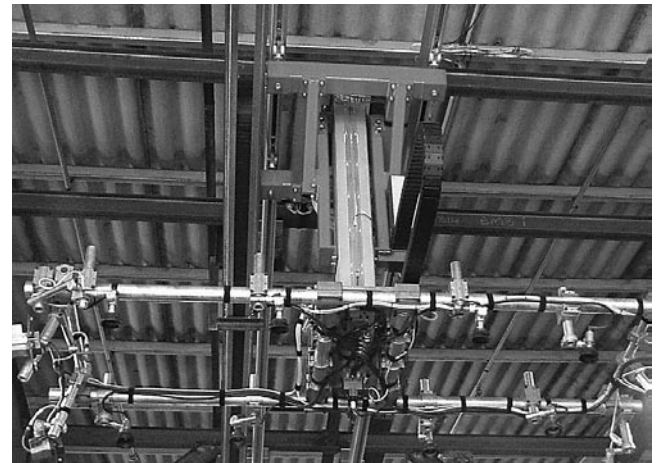
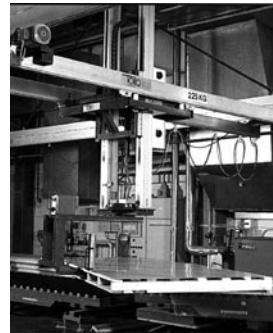
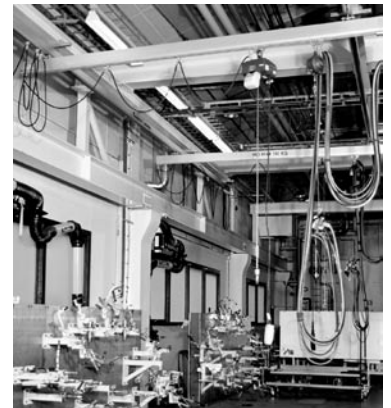
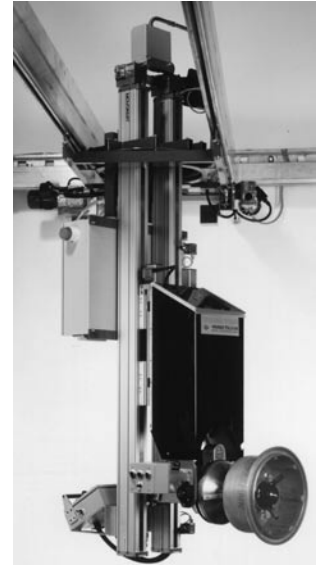

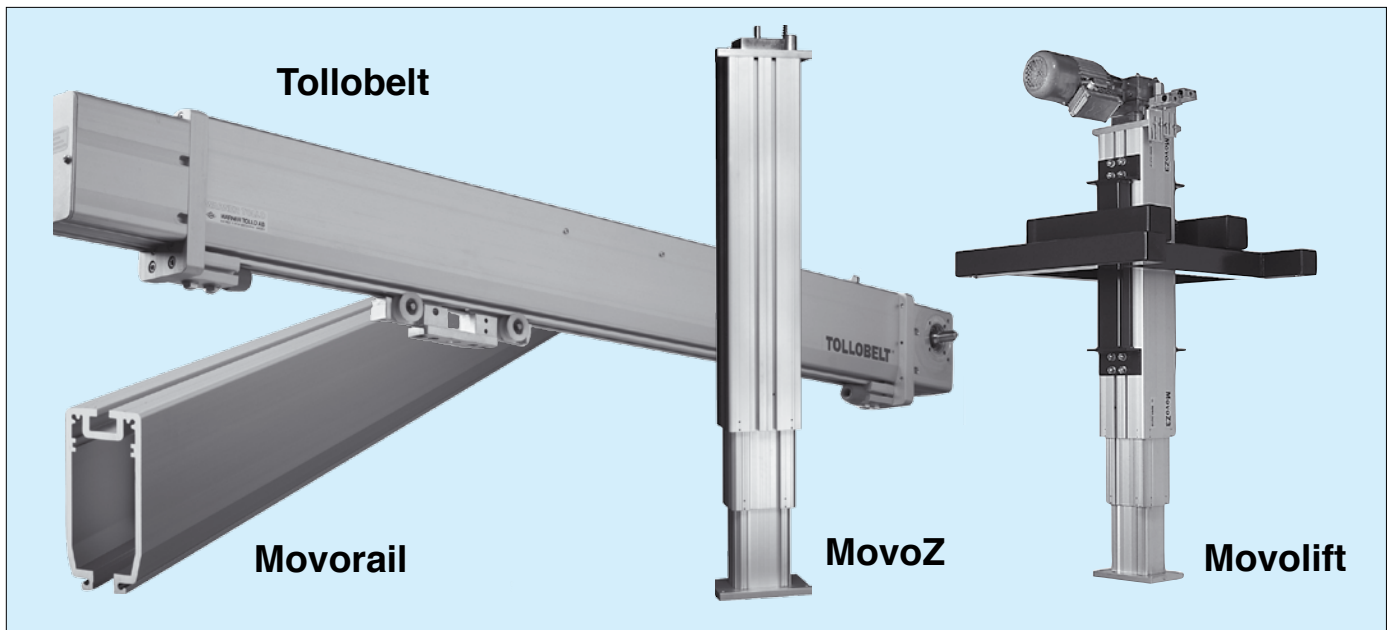

## A complete range

The Thomson Tollo range of material handling units are designed for manual, motorised and automated equipment, in one or multiple axes, for all kinds of industrial handling applications. The range consists of:

- Movorail, an “easy to move” overhead rail system available in a number of sizes.
- Tollobelt, a belt driven high speed linear drive unit for overhead installation with strokes up to 20 meters.
- MovoZ, a series of telescopic space saving linear drive units for lifting applications.
- Movolift, a lifting unit based on MovoZ Z3 fitted with mounting frame, gearbox and motor which can be directly suspended to a Movorail or Tollobelt system.

## Flexibility and versatility

The whole range of units are based on extruded anodised aluminium profiles making them light, easy to install and resistant against corrosion and many chemicals. All units are modular in concept and come with a broad range of accessories so that they can easily be combined into an almost

infinite number of combinations. This makes it easy to design a solution for most tasks in the field of material handling as well as to re-configure an existing system so that it can be re-used in a new configuration.

## Applications

Below is a small selection of all the areas where Thomson Tollo handling equipment can be useful:

- In workshop crane systems for lifting and moving objects up to 600 kg.
- In the automotive industry for the handling and the mounting of doors, hoods, wind shields, roofs, seats, dashboards, motors, wheels, etc.
- In the wood industry for the handling and mounting of boards, plates, doors, windows, etc.
- In the moving and handling of sheet metal, bricks, bags, pallets, boxes, barrels etc.
- At workstations for the suspension of electrical and pneumatic tools.

# Movorail - general product information

## Movorail

Movorail has been proven during more than 20 years of use at companies around the world and has become one of the leading light weight rail systems on the market.

The main reasons for the success of Movorail are light weight, a high degree of modularity, simple and quick installation and a broad range of accessories. This makes it as easy to install a Movorail as it is to move, enlarge, rebuild or rearrange. In other terms, a Movorail system is an investment that can grow and change as demands change.



### Profiles

- Five sizes for a large load range coverage
- Same basic design for all sizes
- Low weight = easy to handle and install
- T-slot for easy and quick suspension
- Built in grooves for installation of current track
- Anodised aluminium profiles = non corrosive
- Over 95% of materials recyclable
- No welding or painting required at installation.

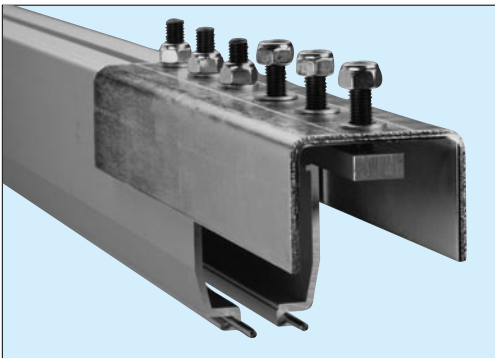

### Rail connections

- Quick to install
- Self aligning
- No drilling required at installation.

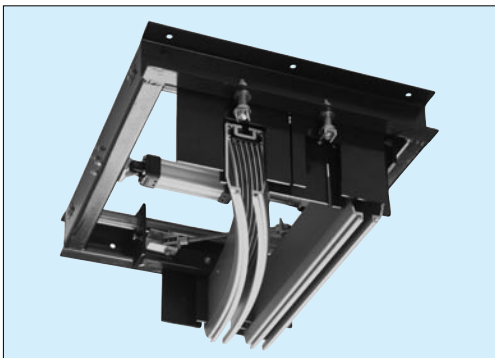

### Switches and turntables

- Makes it possible to design conveyor like systems where trolleys can take different routes.

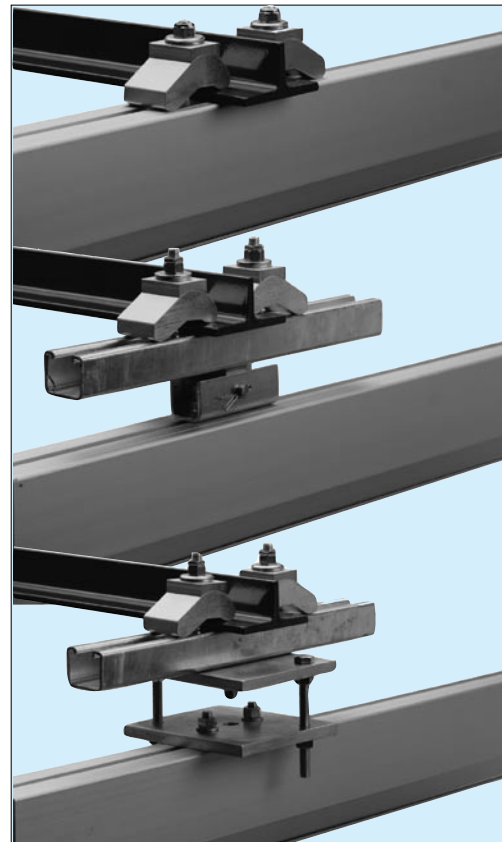

### Suspensions

- For I-beam installation, no drilling required
- Versions for installation to the T-slot or on connections
- Safety cables for enhanced safety available
- Quick and simple installation.

## Movorail



### Trolleys

- Large range of trolleys for different requirements
- Light weight trolleys with ball bearing wheels means easy rolling.
- Quick installation to crane rail
- Safety cables included for each trolley
- Motor trolleys for heavy loads
- Cable trolleys for cables and pneumatic hoses.

Example of a rail system with a double girder crane and a single girder crane.

1. I-beam suspension for installation on a connection
2. Single girder crane rail
3. I-beam clamps for installation on the rail
4. Crab trolley
5. Bogie trolley
6. Connection
7. Current track inserted in rail
8. Double girder crane rails
9. Distance girder
10. Yoke
11. Main girder rails.

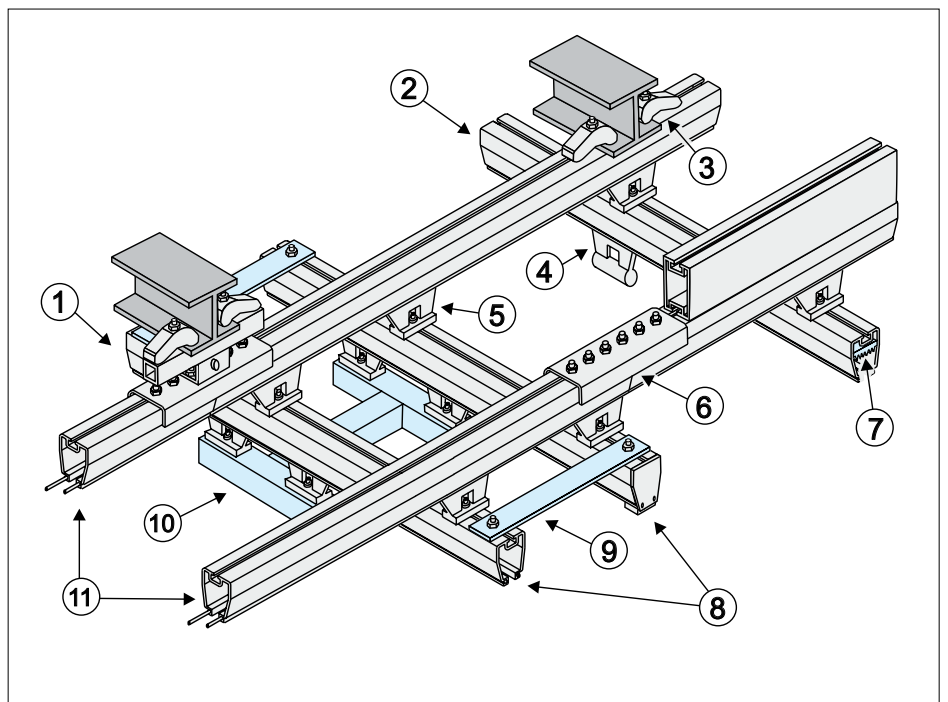

Example of a rail system with telescopic girder crane rails.

When not in use (1) the system is stowed leaving space for conveyor systems and other equipment. When in use (2) the lower crane rail is extended over the work place.

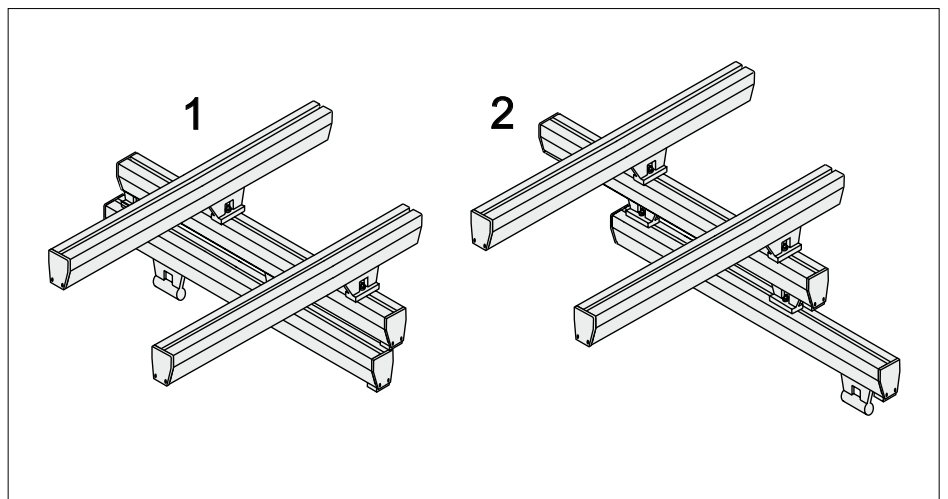

# Movorail SPR 85, SPR 125, SPR 160A, SPR 295B, SPR 295W

## Technical data

Parameters	SPR 85	SPR 125	SPR 160A	SPR 295B	SPR 295W
X (mm)	85	125	160	295	295
C (mm)	68,8	71,5	73,5	73,5	73,5
Profile lengths (m)	4, 5, 6, 8	4, 5, 6, 8	4, 5, 6, 8	4, 5, 6, 8	4, 5, 6, 8
Inertia (cm <sup>4</sup> )	97	333	812	1368	3700
Weight / meter (kg/m)	3	5	7,8	14	14,1

SPR 85, SPR 125, SPR 160A

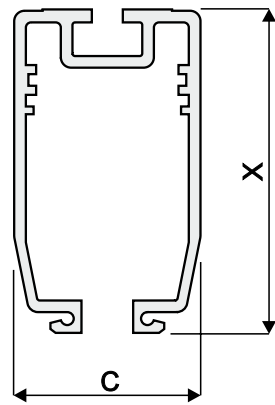

SPR 295B, SPR 295W

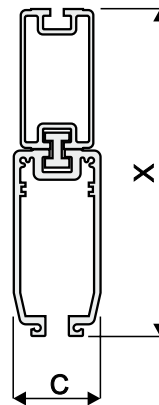

## Deflection of the rails

The diagram is based on a maximum deflection of 1/500 of the distance between the suspensions ( $L_{max}$ ).

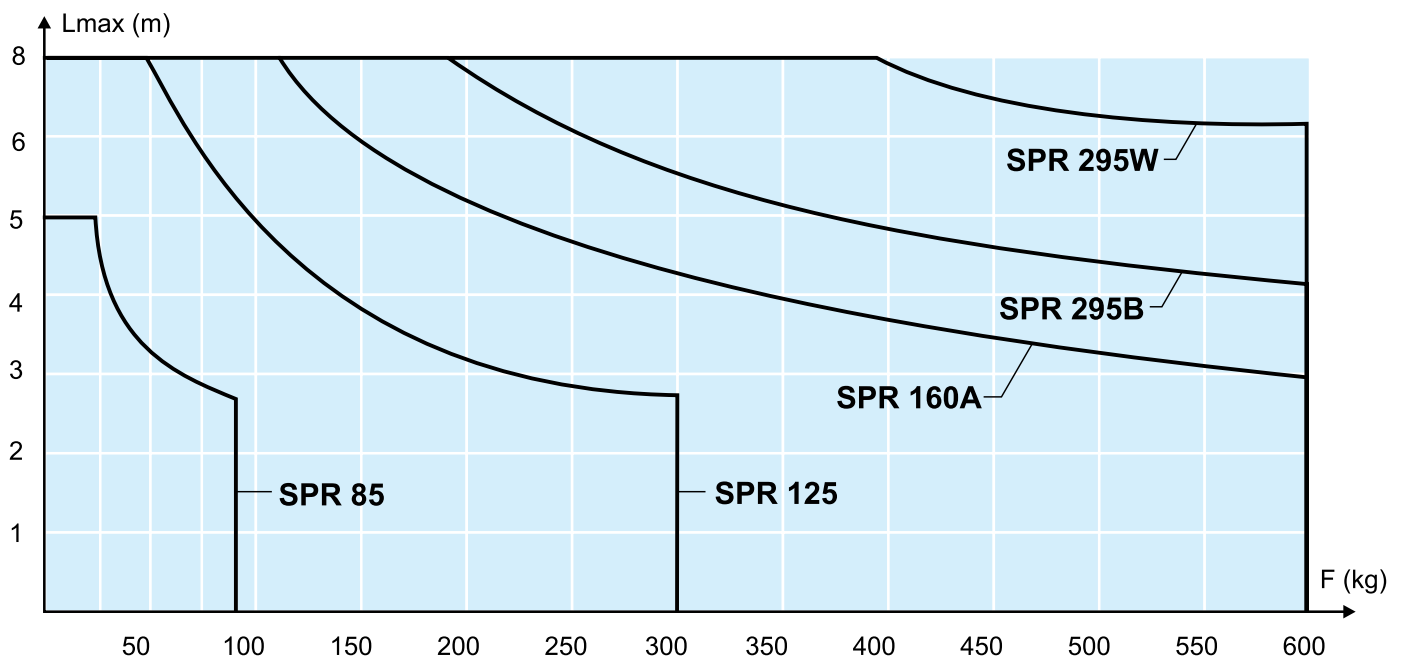
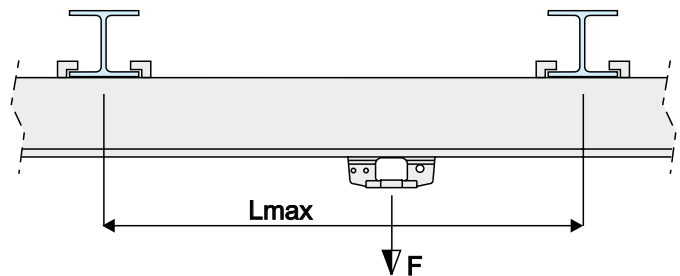



# Movorail SPR 85, SPR 125, SPR 160A, SPR 295B, SPR 295W

## Installation dimensions for standard systems

X-profile	Y-profile	X	Y	A	B	H
SPR 85	SPR 85	85	85	57,5	52	279,5
SPR 85	SPR 125	85	125	58,5	49,5	318
SPR 85	SPR 160A	85	160	58,5	45	348,5
SPR 125	SPR 85	125	85	55	52	317
SPR 125	SPR 125	125	125	56	49,5	355,5
SPR 125	SPR 160A	125	160	56	45	386
SPR 160A	SPR 85	160	85	50,5	52	347,5
SPR 160A	SPR 125	160	125	51,5	49,5	386
SPR 160A	SPR 160A	160	160	51,5	45	416,5
SPR 295•	SPR 85	295	85	50,5	52	482,5
SPR 295•	SPR 125	295	125	51,5	49,5	521
SPR 295•	SPR 160A	295	160	51,5	45	551,5

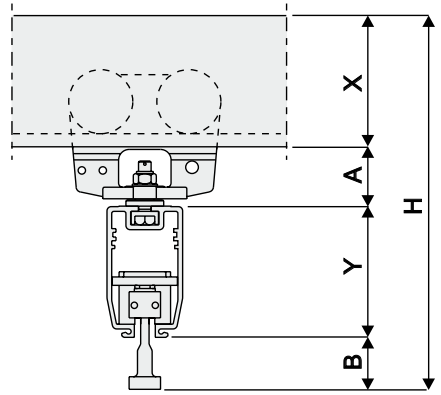
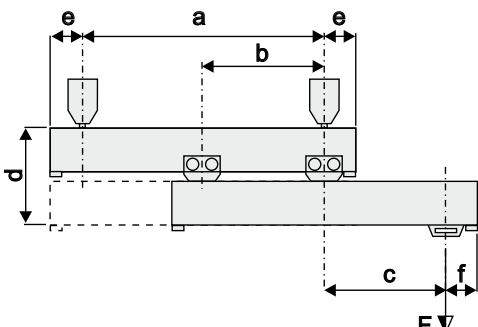

Table valid for BGV trolleys only.

## Installation dimensions and load capacity for systems with telescopic crane rail

X-profile	Y-profile	a	b	c	d	e	f	Max. load F (N)
SPR 85	SPR 85	2000	1000	1000	229	250	200	400
SPR 85	SPR 85	3000	1500	1000	229	250	200	300
SPR 85	SPR 85	4000	2000	1000	229	250	200	250
SPR 125	SPR 125	2000	1000	1000	307	250	200	1400
SPR 125	SPR 125	3000	1500	1000	307	250	200	1000
SPR 125	SPR 125	4000	2000	1000	307	250	200	900
SPR 160A	SPR 160A	2000	1000	1000	372	250	200	3000
SPR 160A	SPR 160A	3000	1500	1000	372	250	200	2500
SPR 160A	SPR 160A	4000	2000	1000	372	250	200	2000



The table above shows a few examples of possible combinations of loads and dimensions.

## Tollo motor trolley dimensions

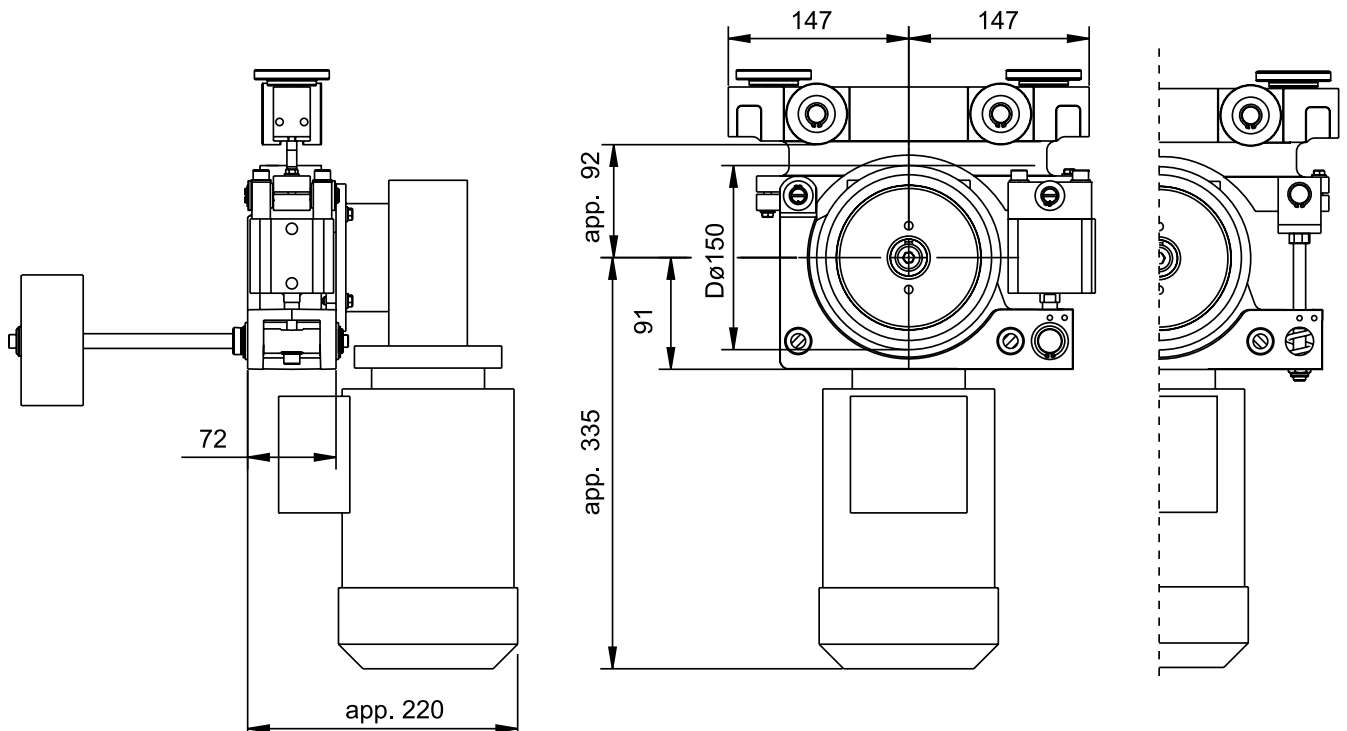

## Ordering key for Tollo motor trolleys with motor

Designation example	<b>TMT</b>	<b>125</b>	<b>S</b>	<b>B</b>	<b>20</b>	<b>A</b>	<b>7</b>	<b>-2</b>	<b>N</b>
<b>Unit type</b> Tollo Motor Trolley	<b>TMT</b>								
<b>Profile size</b> SPR 125 SPR 160A		<b>125</b> <b>160</b>							
<b>Type of TMT trolley</b> Spring loaded drive wheel (standard) Pneumatically released drive wheel Spring loaded drive wheel and power pick up Pneumatically released drive wheel and power pick up			<b>S</b> <b>P</b> <b>T</b> <b>Q</b>						
<b>Colour</b> Blue (standard) Yellow				<b>B</b> <b>Y</b>					
<b>Speed of trolley at nominal motor speed</b> 20 m/min 25 m/min 30 m/min 35 m/min 40 m/min 50 m/min 60 m/min					<b>20</b> <b>25</b> <b>30</b> <b>35</b> <b>40</b> <b>50</b> <b>60</b>				
<b>Motor, gear and drive wheel configuration</b> 3 x 400 Vac SEW motor, SEW gear and drive wheel (standard)						<b>A</b>			
<b>Motor size</b> IEC 71 IEC 80							<b>7</b> <b>8</b>		
<b>Motor poles</b> 2 pole 4 pole 8/2 pole (two speed motor)								<b>-2</b> <b>-4</b> <b>82</b>	
<b>Type of motor brake</b> No brake Electromagnetic fail safe brake Electromagnetic fail safe brake with hand release									<b>N</b> <b>B</b> <b>H</b>

## How to order and select Movorail components

The complete range of Movorail components and part numbers can be found in the Movorail Project Specification. Information about the motor trolleys can also be found in the Tollo Motor Trolley folder.

The Thomson Tollo Movorail Sizing & Selection software will assist you when calculating the requirements of your system and guide you through the process of choosing the correct components.

The Project Specification, the Motor Trolley folder and the Sizing and Selection software can be obtained free of charge.

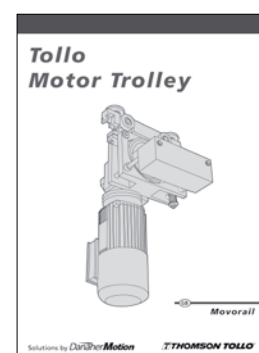
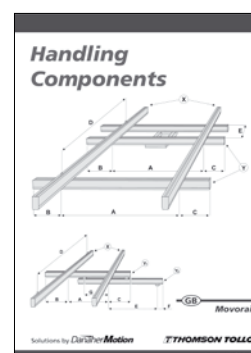

## Tollobelt TBR1, TBR2, TBR3 and TBR4

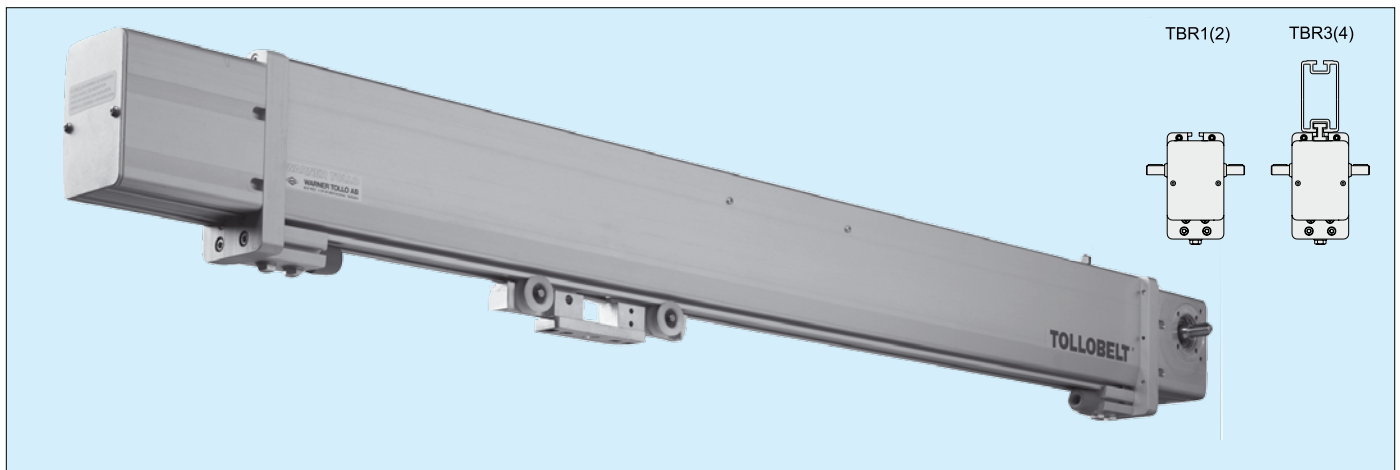

### Belt drive, roller guide

- Four sizes
- Belt drive
- Ball bearing trolleys
- Speed up to 5 m/s
- Stroke up to 20 m
- Load up to 600 kg
- One to four trolleys possible.

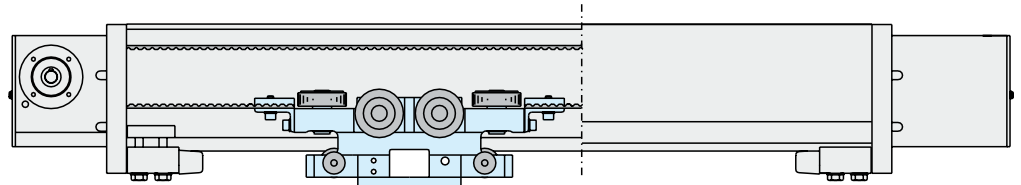

## General

Parameters	TBR1	TBR2	TBR3	TBR4
Weight per trolley (kg)	3,5	3,5	3,5	3,5
Max. input speed (rpm)	1250	1250	1250	1250
Move (mm/revolution)	240	240	240	240
Ambient temperature (°C)	-20 to 70	-20 to 70	-20 to 70	- 20 to 70
Weight with single trolley (kg/m)	11,5 + L × 6,3	13,5 + L × 9,1	13,5 + L × 16,3	13,5 + L × 16,3

## Load capacity

Parameters	TBR1	TBR2	TBR3	TBR4
Max. stroke (m)	15	20	20	20
Fx max. (N)	800	1250	1250	1250
Fz max. (N)	3000	6000	6000	6000
Max. speed (m/s)	5	5	5	5
Repeatability (±mm)	0,5	0,5	0,5	0,5
Resolution (mm)	1	1	1	1

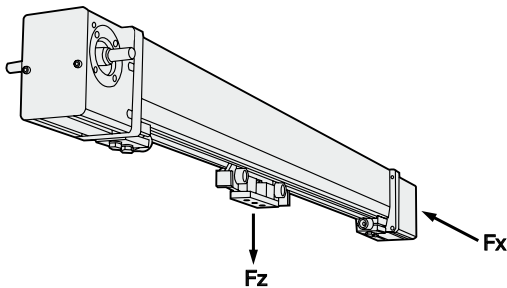

## Deflection of the beam

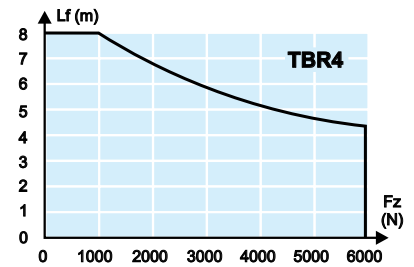
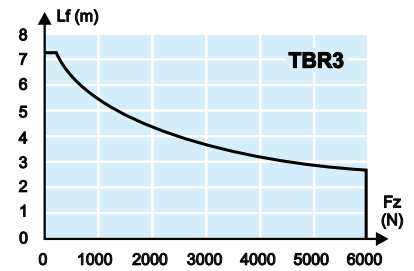
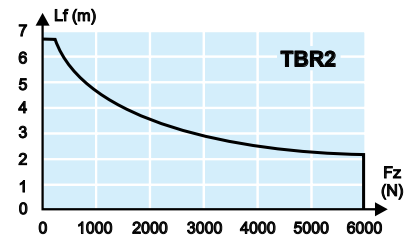
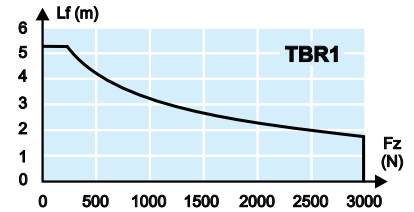
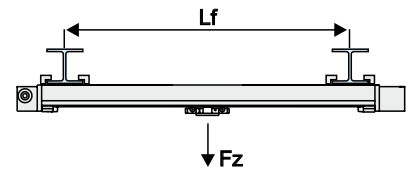

## Length of profile sections and number of connections

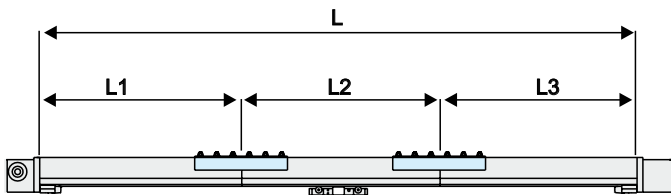

L (ordering length in cm)						
	0 – 800	801 – 1200	1201 – 1400	1401 – 1600	1601 – 1800	1801 – 2000
L1 (cm)	0 – 800	600	600	800	600	600
L2 (cm)		201 – 600	601 – 800	601 – 800	600	600
L3 (cm)					401 – 600	601 – 800

Note! sectioning can be done in other ways if agreed before order.

## Dimensions

Designation: TBR1(2)B240 .....

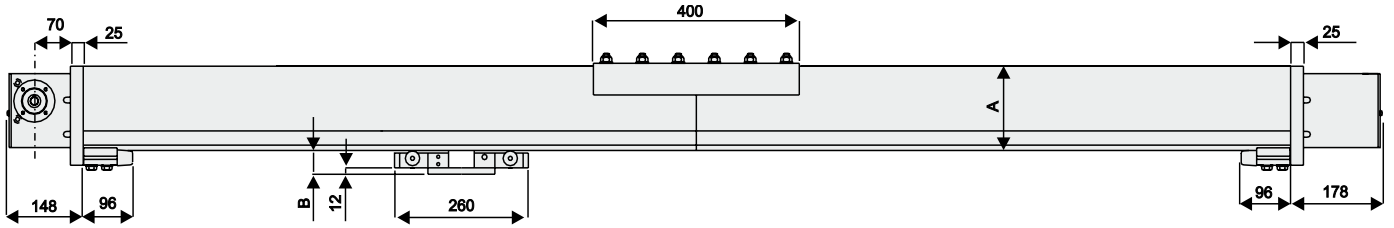

Designation: TBR3(4)B240 .....

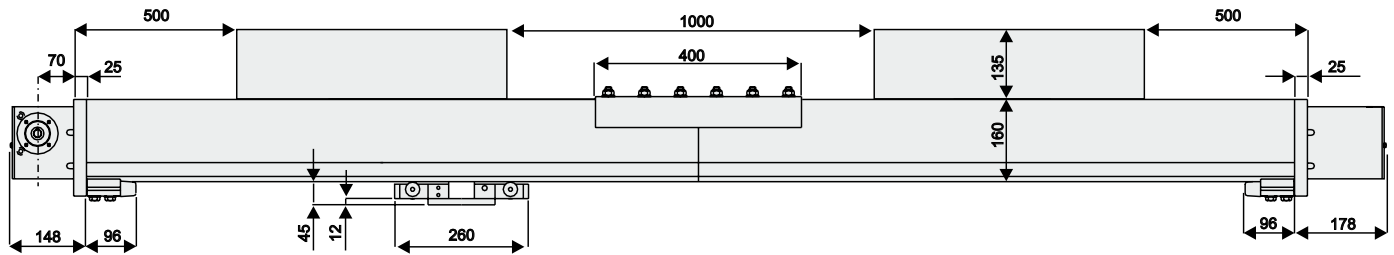

	TBR1	TBR2(3/4)
A	125	160
B	50	45
C	11	15
D	0	34
E	62,5	66,5

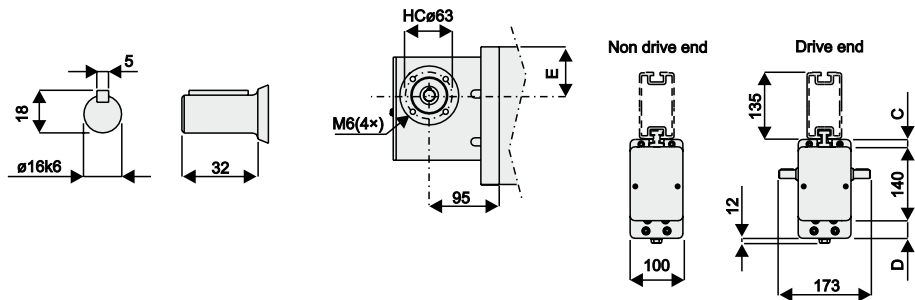

## Ordering length

### A-trolley

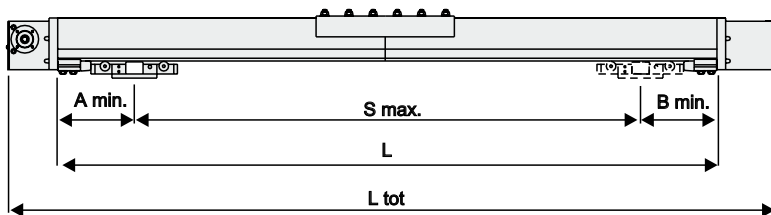

### C-trolley

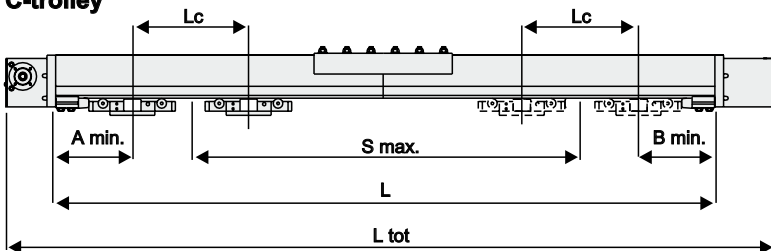

	A min.	B min.	Trolley c/c distance*	Ordering length	Total length
TBR •	226	226	Lc Lc min = 410	L L = S max. + Lc + A min + B min	L tot L tot = L + 326

\* For A-trolleys, Lc = 0 mm

## Tollobelt

Designation example	<b>TB</b>	<b>R</b>	<b>1</b>	<b>B</b>	<b>240</b>	<b>C</b>	<b>700</b>	<b>1000</b>
<b>Unit type</b> Tollobelt	TB							
<b>Guide</b> Roller guide		R						
<b>Profile height</b> 125 mm 160 mm 295 mm, bolted version 295 mm, welded version			1 2 3 4					
<b>Drive mechanism</b> Belt drive				B				
<b>Linear move per input shaft revolution</b> 240 mm					240			
<b>Number of trolleys</b> One trolley Two trolleys Three trolleys Four trolleys						A B C D		
<b>Lc distance between trolleys in cm</b> One trolley Multiple trolleys (specify distance)							000 ...	
<b>Ordering length in cm</b>								....

## Worm gear type TBS40

The worm gear is installed directly to the unit while the motor has to be installed to an intermediate bell house flange which includes a matching coupling. The gear and the bell house are ordered separately.

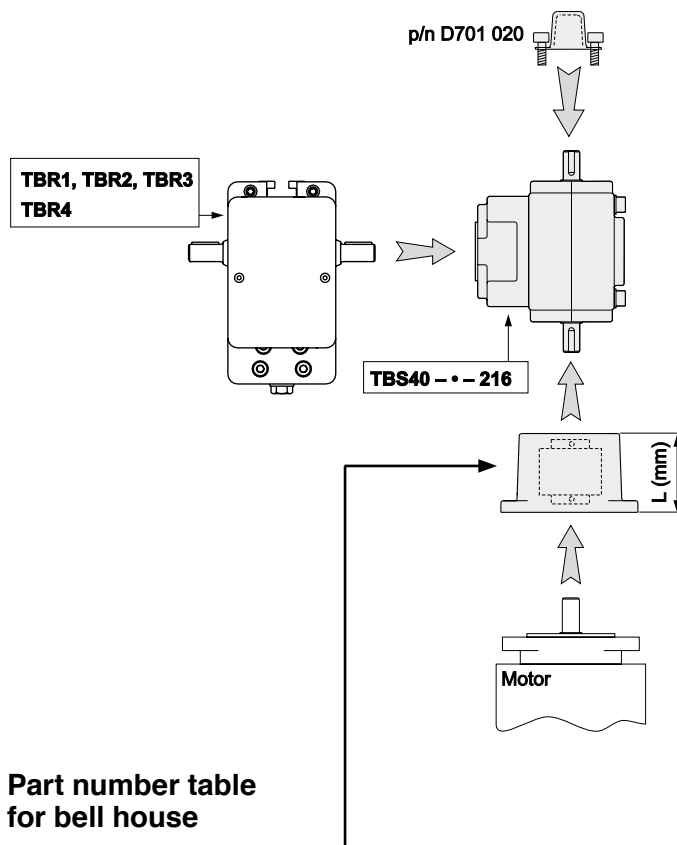

Part number table for bell house

Bell house		
IEC 71 B14	IEC 80 B14	Servo 95
L = 58	L = 68	L = 78
D701 011	D701 015	D389 825

## TBS40

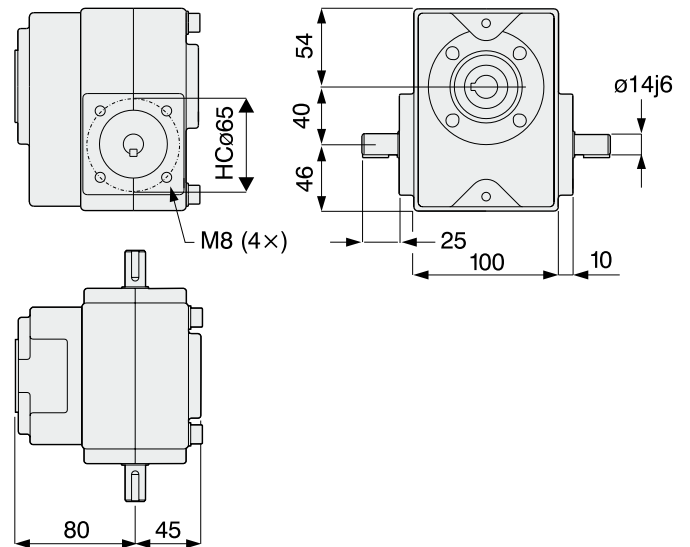

## Ordering key for worm gear TBS40

Example: TBS40- 5,5 -216

### Gear ratio

3	3
5,5	5,5
7,5	7,5
10	10
15	15
20	20
24	24
30	30
40	40
48	48
60	60

## Motor size table



Keep in mind that heavy motors will need extra support in order not to break the flange or gear due to the load torque created.

Motor size	A	D	L	HC	d
IEC 63 B14	60	11	23	75	M5
IEC 71 B14	70	14	30	85	M6
IEC 80 B14	80	19	40	100	M6
IEC 90 B14	95	24	50	115	M8
IEC 100/112 B14	110	28	60	130	M8
Servo 80*	80	14	30	100	ø7
Servo 95*	95	19	40	115	ø9
Servo A200	130	24	50	165	ø11

\* Measures according to DIN 42950.

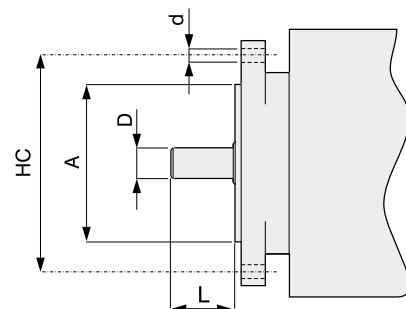

## Intermediate shafts

The intermediate shafts provides synchronous drive of multiple Tollobelt units with a single motor.

The intermediate shaft type DSP consists of couplings matching the drive shaft of the Tollobelt units and a high precision tube with customer defined length.

The intermediate shaft has a critical speed which may not be exceeded. The critical speed is a function of the length of the tube, as diagrammed below. Higher speed or longer transmissions require additional support bearings which can be ordered from your local bearing supplier.

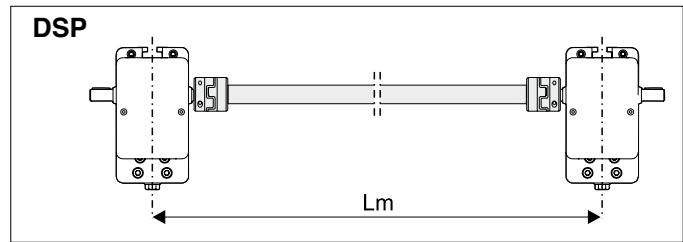

### Technical data

	DSP
Weight (kg)	$1,3 + 0,026 \times (Lm - 20)$
Max. speed (rpm)	1500
Diameter (mm)	30

### Ordering information

#### Designation for DSP

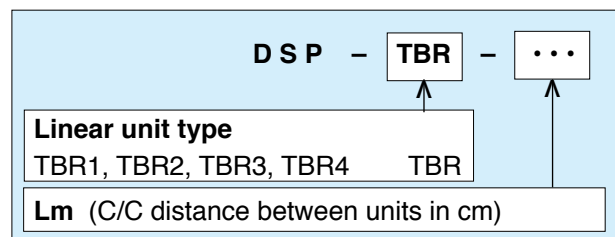

### Critical speed

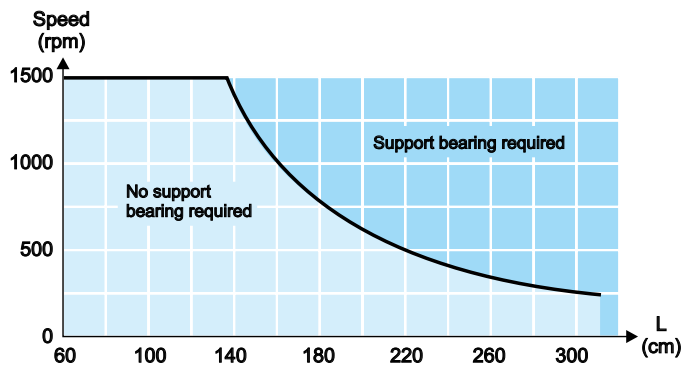

## Accessories

### Brackets for mechanical limit switch

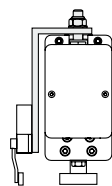

	TBR1	TBR2	TBR3(4)
	D390 017	D390 016	D390 015

### Shaft cover

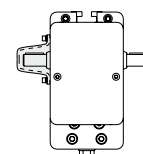

	TBR1(2/3/4)
	D700 178

### T-slot bolts

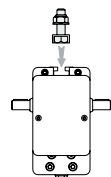

	TBR1(2/3/4)		
	M12 h = 26 D102 510	M12 h = 42 D102 530	M12 h = 89 D102 520

### Flexible trolley bolt connection

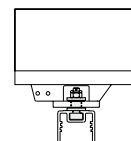

	TBR1(2/3/4)
	D105 710



## MovoZ Z2

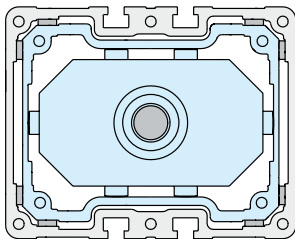
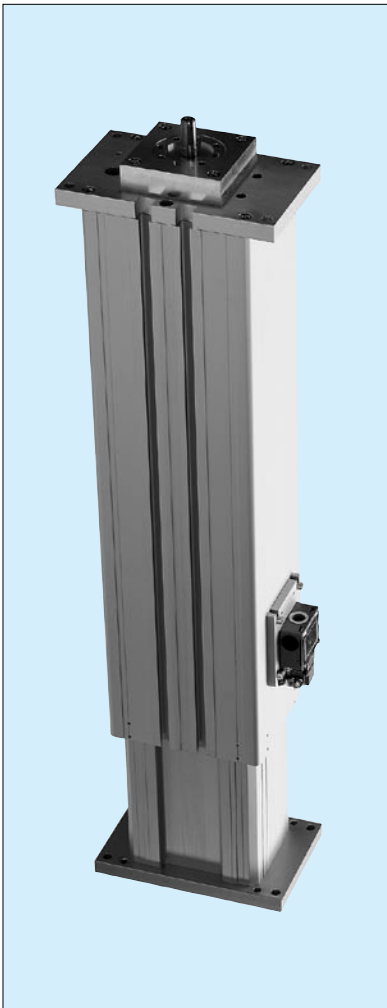

### Screw drive, sliding guide

- Telescopic movement (double profiles)
- Can be installed in any desired direction
- Built in end of stroke limit switches
- Short retracted length
- High load
- High side load capacity
- Space-saving
- High torsion strength

## MovoZ Z3

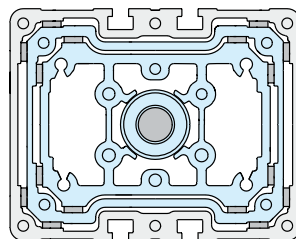
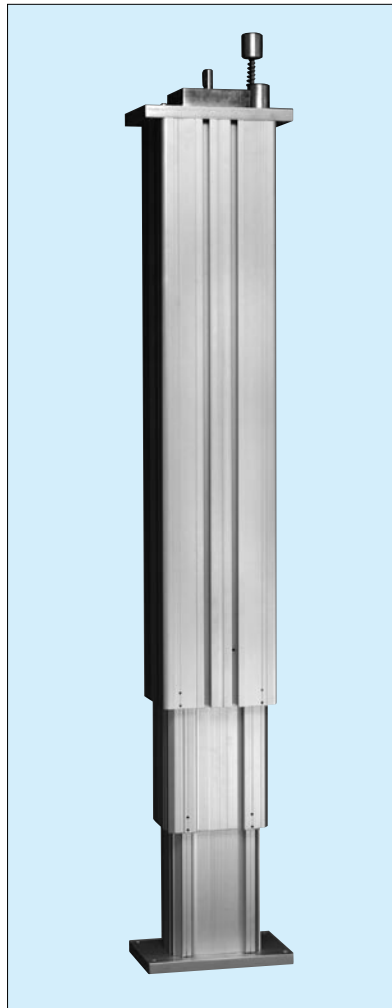

### Screw drive, sliding guide

- Telescopic movement (triple profiles)
- Only for lifting applications
- Very short retracted length
- High load
- High side load capacity
- Space-saving
- High torsion strength

## General

Parameters	MGZ2K2510	MGZ2K2525	MGZ2K3220
Max. input speed (rpm)	3000	2400	3000
Ambient temperature (°C)	-20 to 70	-20 to 70	-20 to 70
Weight (kg)	9,5 + 0,25 × L min.	9,5 + 0,25 × L min.	13 + 0,28 × L min.

## Load capacity

Parameters	MGZ2K2510	MGZ2K2525	MGZ2K3220
Max. stroke (m)	1,5	1,5	1,5
Fz max. (N)	5000	5000	7500
L max. (mm)	4000	4000	4000
Mx max. (Nm)	700	700	700
My max. (Nm)	700	700	700
Mz max. (Nm)	330	330	330
Mta max. (Nm)	45	45	93
Frd max. (N)	1000	1000	1200
Max. speed (m/s)	0,5	1,0	1,0
Repeatability (±mm)	0,1	0,1	0,1
Screw lead (mm/rev.)	10	25	20
Screw diameter (mm)	25	25	32

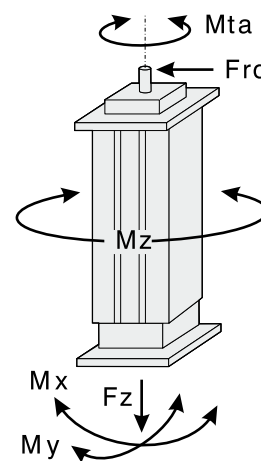

## Dimensions

Designation: MGZ2K ..... **MGZ2K2510(25)**

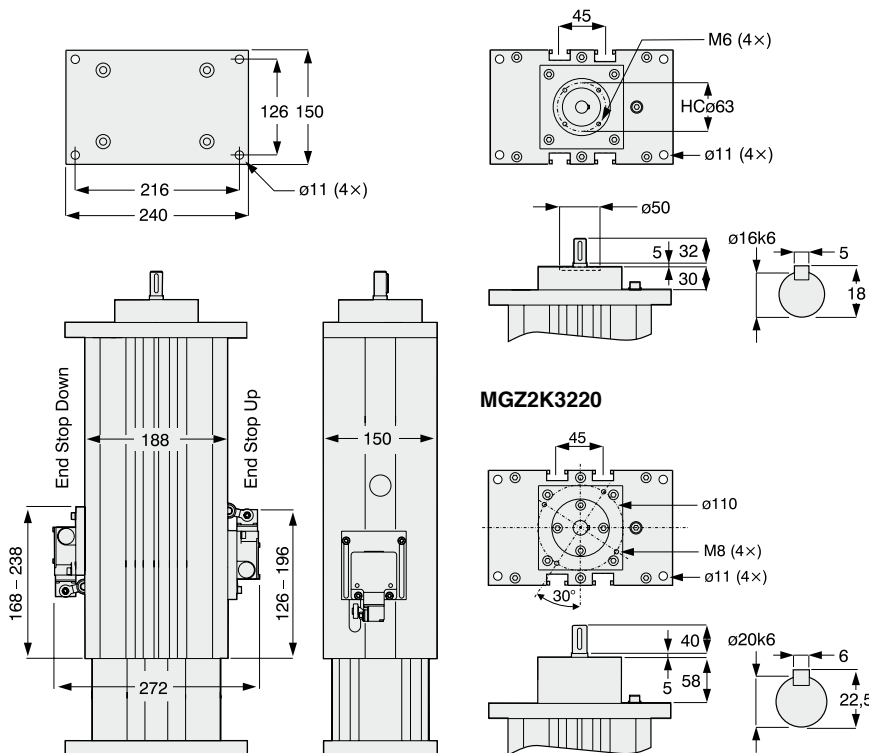

Standard version    Elongated version

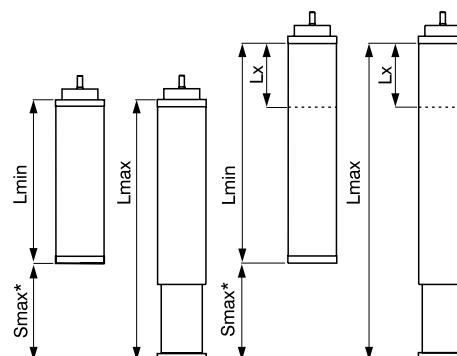

\* Smax = maximum stroke between the mechanical stops of the unit (theoretical stroke). Safe stroke is normally about 100 mm shorter (practical stroke).

## Ordering length (all dimensions in cm)

Min. retracted length	Max. extended length
$L_{min} = S_{max} + L_x^{**} + 38$	$L_{max} = L_{min} + S_{max}$

\*\* Lx = optional extra length which makes the unit longer but does not add to the stroke.

## General

Parameters	MGZ3K2510	MGZ3K2525	MGZ3K3220
Max. input speed (rpm)	3000	2400	2500
Ambient temperature (°C)	-20 to 70	-20 to 70	-20 to 70
Weight (kg)	14 + 0,42 × L min.	14 + 0,42 × L min.	15 + 0,45 × L min.

## Load capacity

Parameters	MGZ3K2510	MGZ3K2525	MGZ3K3220
Max. stroke (m)	1,5	1,5	1,5
Fz max. (N)	5000	5000	7500
L max. (mm)	4000	4000	4000
Mx max. (Nm)	2000	2000	2000
My max. (Nm)	2000	2000	2000
Mz max. (Nm)	330	330	330
Mta max. (Nm)	45	45	93
Frd max. (N) 1000	1000	1000	1200
Max. speed (m/s)	0,5	1,0	0,8
Repeatability (±mm)	0,1	0,1	0,1
Screw lead (mm/rev.)	10	25	20
Screw diameter (mm)	25	25	32

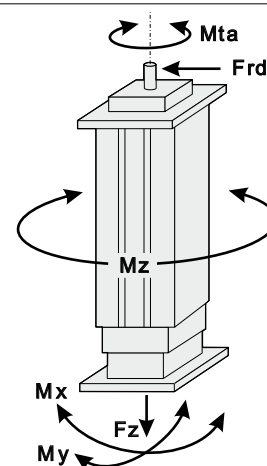

## Dimensions

Designation: MGZ3K ..... **MGZ3K2510(25)**

Standard version Elongated version

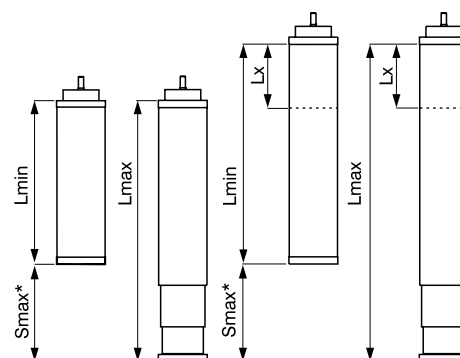
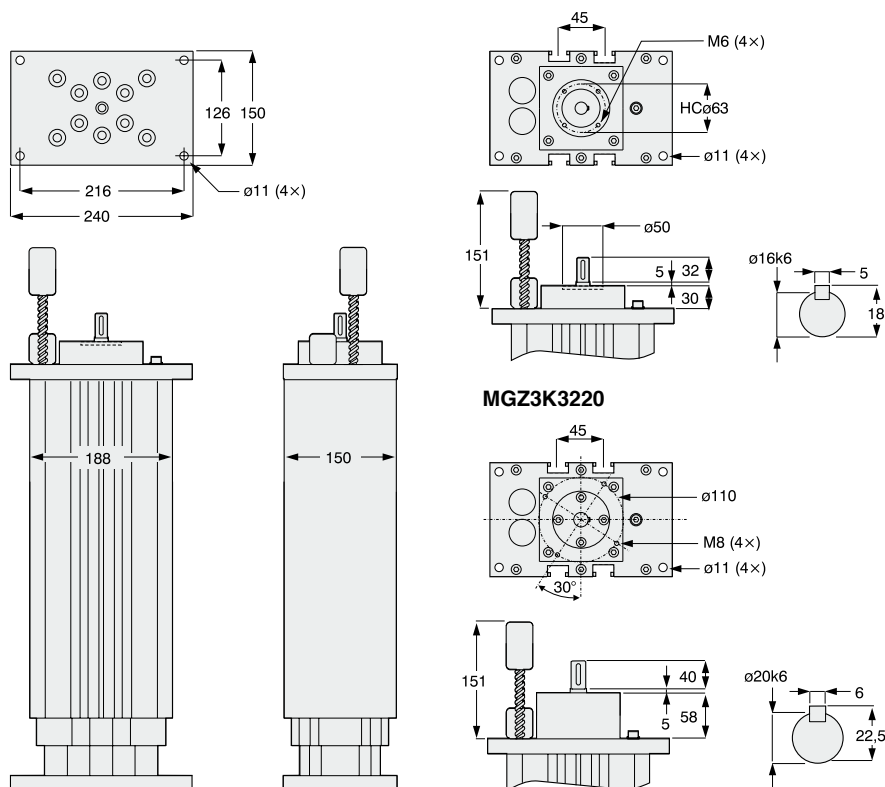

\* Smax = maximum stroke between the mechanical stops of the unit (theoretical stroke). Safe stroke is normally about 100 mm shorter (practical stroke).

Ordering length (all dimensions in cm)

Min. retracted length	Max. extended length
$L_{min} = S_{max} + L_{x}^{**} + 17$	$L_{max} = 2 \times S_{max} + L_{x}^{**} + 17$

\*\* Lx = optional extra length which makes the unit longer but does not add to the stroke.

## MovoZ Z2 and Z3

Designation example	M	G	Z3	K	25109	250	450
<b>Unit type</b> Linear unit	M						
<b>Guide type</b> Sliding guide		G					
<b>Size</b> Z2 Z3			Z2 Z3				
<b>Drive type</b> Ball screw and ball nut				K			
<b>Screw diameter / screw lead / tolerance class</b> 25 mm / 10 mm / T9 25 mm / 25 mm / T9 32 mm / 20 mm / T7					25109 25259 32207		
<b>Minimum retracted length in cm (L min.)</b>						...	
<b>Maximum extended length in cm (L max.)</b>							...

## Flanges and gears

### Belt gear type BGM40

The belt gear is installed directly on to the shafts of the motor and the actuator. No couplings are required. The belt gears are maintenance free.

### Ordering key

Example:	BGM40-	2	-KK	080	P	07
<b>Gear ratio</b> 1,00 2,14 3,00		1 2 3				
<b>Motor size</b> IEC 71 B14 IEC 80 B14 Servo 80 Servo 95			071 080 S80 S95			
<b>Linear drive unit</b> Z2 (only models with 25 mm screw diameter)						07

### BGM40

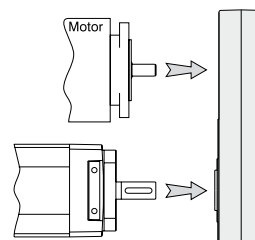
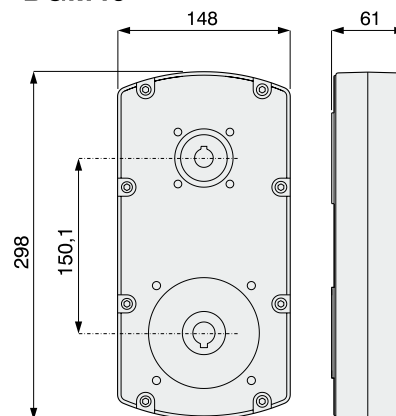

## Worm gear type TBS40

The worm gear is installed directly to the unit while the motor has to be installed to an intermediate bell house flange which includes a matching coupling. The gear and the bell house are ordered separately. Note! The worm gear only fits models with 25 mm screw diameter.

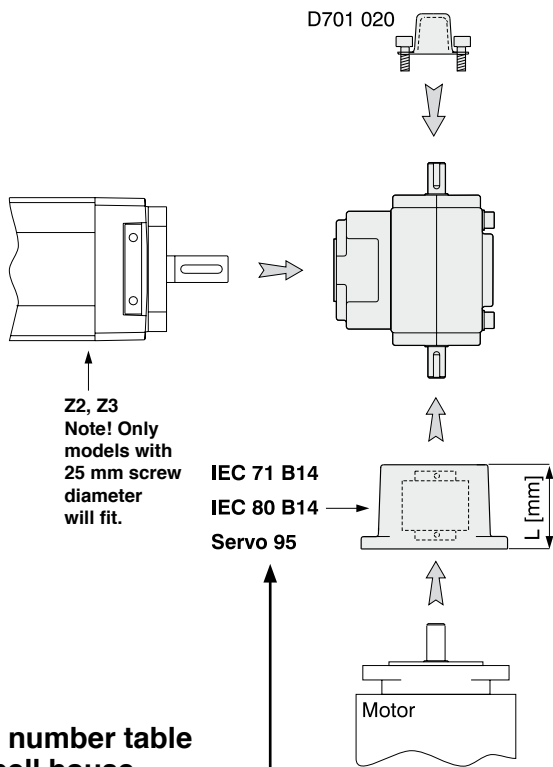

Part number table for bell house

Bell house		
IEC 71 B14	IEC 80 B14	Servo 95
L = 58	L = 68	L = 78
D701 011	D701 015	D389 825

## TBS40

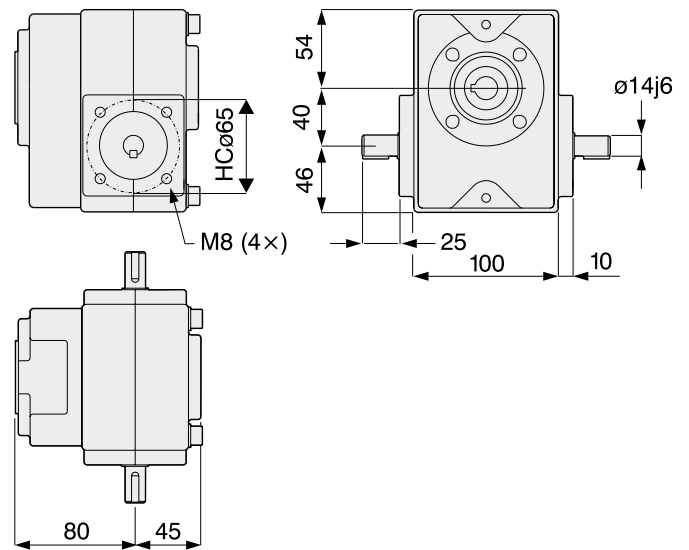

## Ordering key for worm gear TBS40

Example: TBS40- 5,5 -216

Gear ratio	
3	3
5,5	5,5
7,5	7,5
10	10
15	15
20	20
24	24
30	30
40	40
48	48
60	60

## Motor size table



Keep in mind that heavy motors will need extra support in order not to break the flange or gear due to the load torque created.

Motor size	A	D	L	HC	d
IEC 63 B14	60	11	23	75	M5
IEC 71 B14	70	14	30	85	M6
IEC 80 B14	80	19	40	100	M6
IEC 90 B14	95	24	50	115	M8
IEC 100/112 B14	110	28	60	130	M8
Servo 80*	80	14	30	100	ø7
Servo 95*	95	19	40	115	ø9
Servo A200	130	24	50	165	ø11

\* Measures according to DIN 42950.

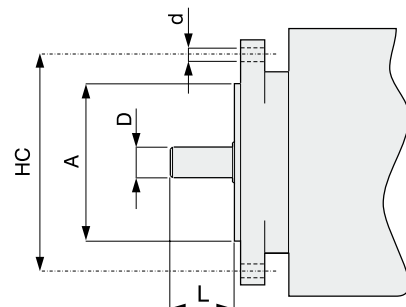

<b>Z2 and Z3 mounting frame</b>	
<b>Z2/Z3</b>	
	D800 250

<b>Magnetic sensor</b>		
Max. power: 10 W Max. voltage: 100 Vdc Max. current: 0,5 A Lead data: 2 x 0,12 mm <sup>2</sup>		
<b>Z2/Z3</b>		
	Normally open D535 070	Normally closed D535 071

<b>Mounting rail for magnetic sensor</b>	
<b>Z2/Z3</b>	
	L = 1000 D800 223

<b>T-slot bolts</b>		<b>Z2/Z3</b>
		M10 h = 28 D800 089

<b>Limit switch bracket*</b>		<b>Z3</b>
		D800 042

\* Suitable limit switch: Telemecanique XCK-M115

## Movolift

Consists of a MovoZ Z3 unit fitted with mounting frame, gearbox, three phase asynchronous brake motor and limit switches, prepared for suspension in a Movorail or Tollobelt system.

- Stroke up to 1,5 m
- Safety nut
- Lifting speed up to 0,4 m/s
- Load up to 7500 N
- Three types of frames available:  
frame without rotation, frame with  $\pm 360^\circ$  manual rotation and frame with  $\pm 360^\circ$  motorized rotation.

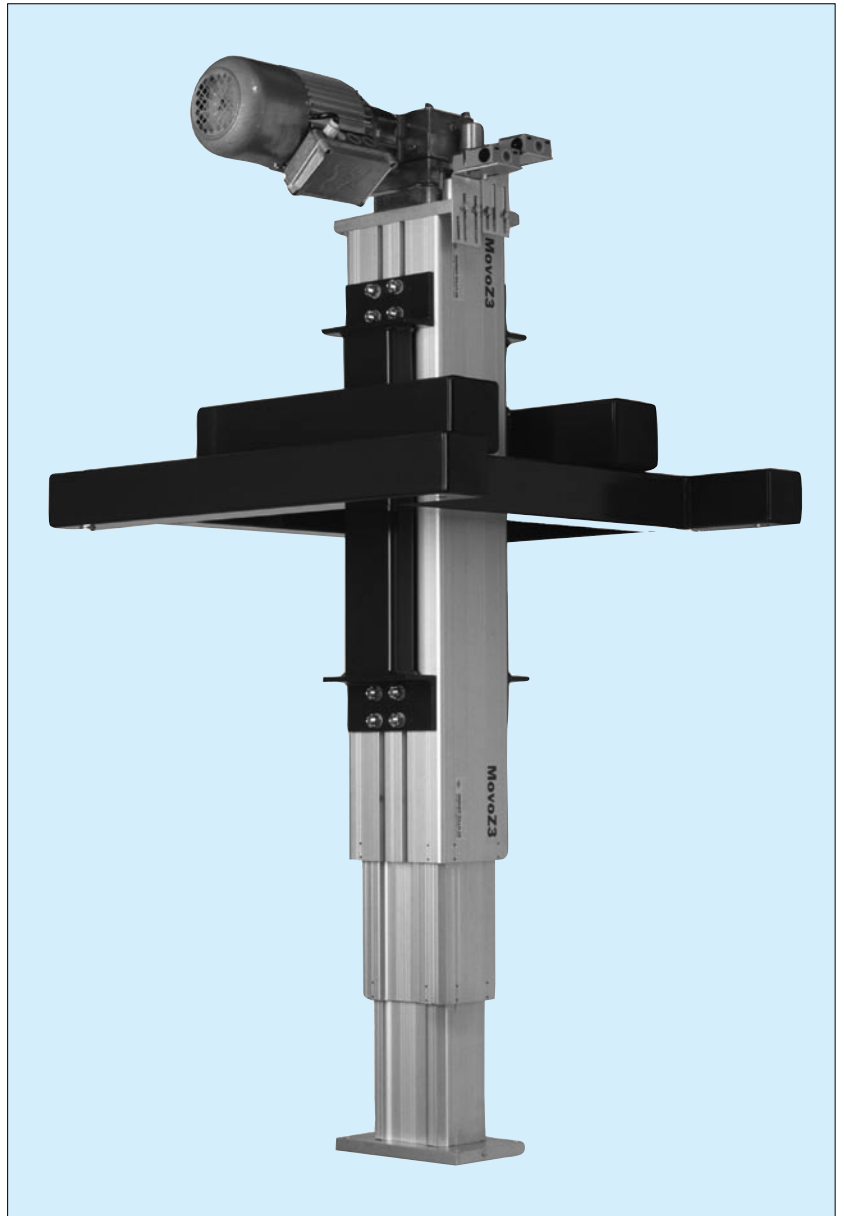
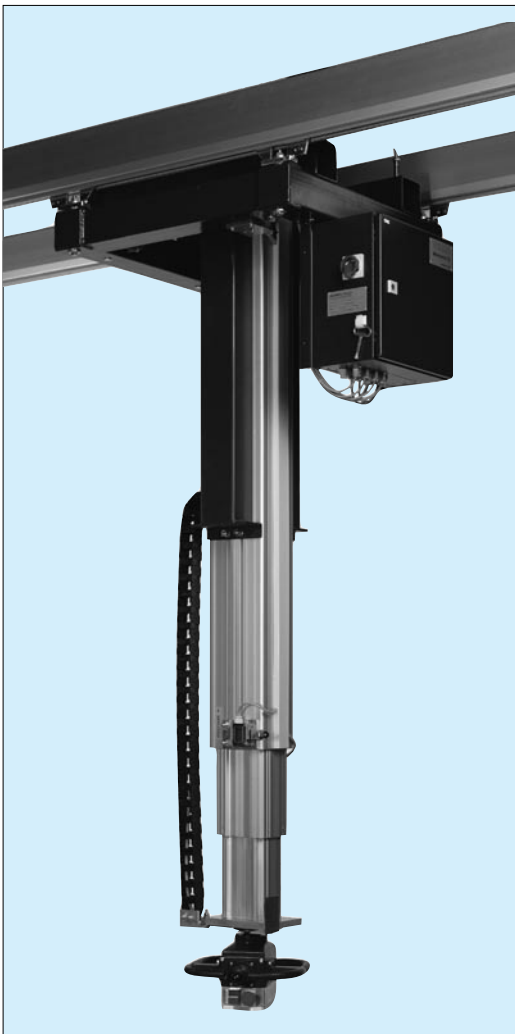

## General

Parameters	MLZ31	MLZ33	MLZ35	MLZ37	MLZ39
Lifting motor	3 × 230/400 Vac 50 Hz 1,1 kW 230 Vac brake	3 × 230/400 Vac 50 Hz 1,1 kW 230 Vac brake	3 × 230/400 Vac 50 Hz 1,1 kW 230 Vac brake	3 × 230/400 Vac 50 Hz 2,2 kW 230 Vac brake	3 × 230/400 Vac 50 Hz 2,2 kW 230 Vac brake
Ambient temperature (°C)	-20 to 70	-20 to 70	-20 to 70	-20 to 70	-20 to 70
Weight without rotation, type A (kg)	140 + Max. retracted × 0,42			150 + Max. retracted × 0,44	
Weight with manual rotation, type B (kg)	235 + Max. retracted × 0,42			245 + Max. retracted × 0,44	
Weight with motorized rotation, type C (kg)	280 + Max. retracted × 0,42			290 + Max. retracted × 0,44	

## Load capacity

Parameters	MLZ31	MLZ33	MLZ35	MLZ37	MLZ39
Max. lifting stroke (m)	1,5	1,5	1,5	1,5	1,5
Fz max. lifting load. (N)	5000*	2400*	1100*	7500*	3500*
Mx max. (Nm)	2000	2000	2000	2000	2000
My max. (Nm)	2000	2000	2000	2000	2000
Mz max. (Nm)	330	330	330	330	330
Max. lifting speed (m/s)	0,09	0,2	0,4	0,13	0,3

\* The max. lifting capacity for any application ultimately depends on the values for Mx, My and Mz

## Rotation data

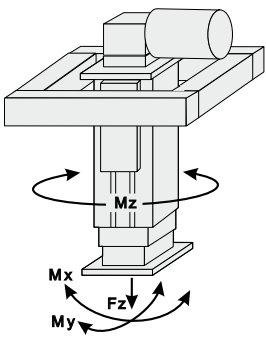
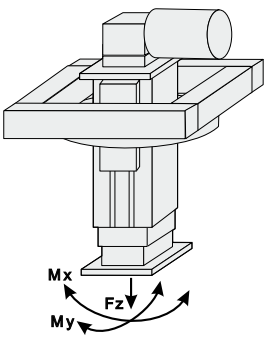
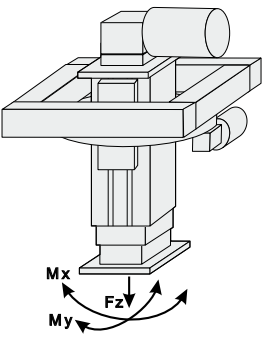
Parameters	MLZ3 · A	MLZ3 · B	MLZ3 · C
Type of rotation	none	manual ± 360°	motorized ± 360°
Rotation motor	–	–	3 × 230/400Vac 50 Hz 0,37 kW
Max. rotation speed (rpm)	–	–	10 rpm
Anti back driving mechanism	–	no	yes, self-locking
			



## Dimensions

Designation: MLZ31(3/5/7/9)A ······

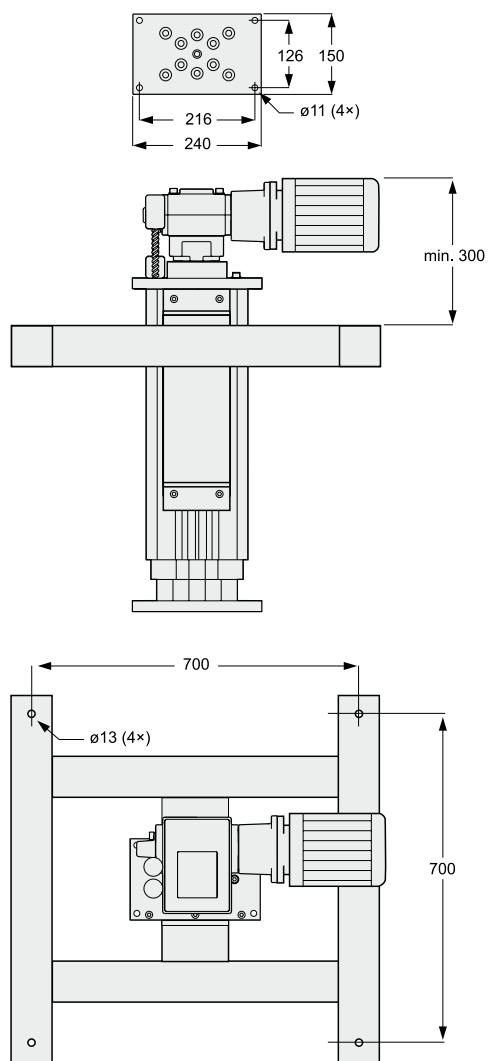

Designation: MLZ31(3/5/7/9)B(C) ······

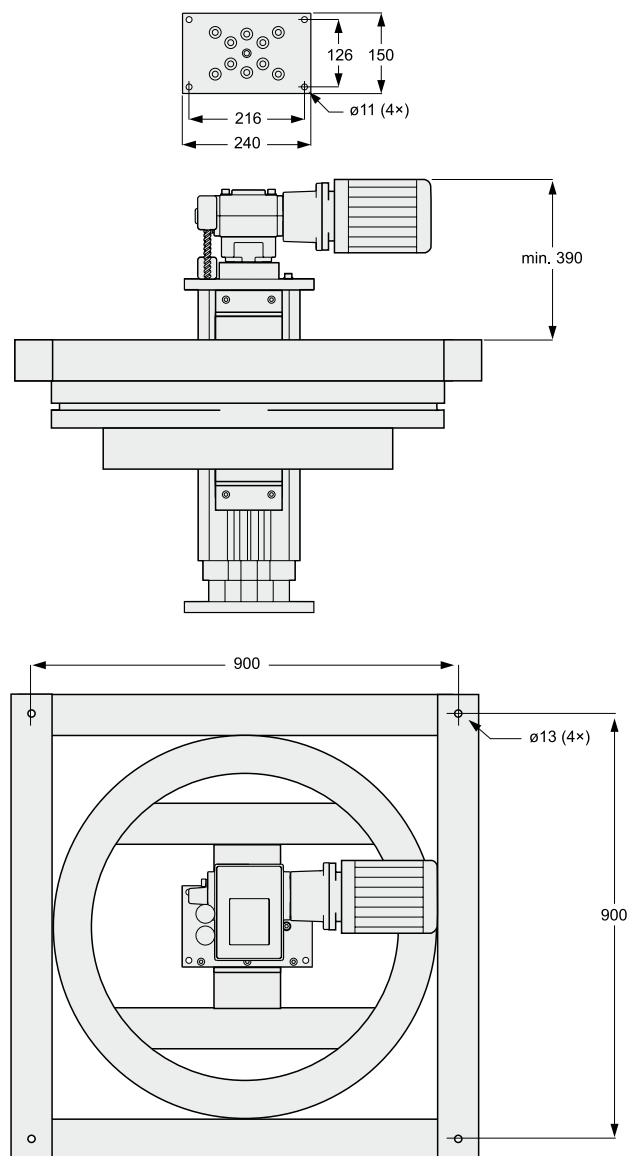

## Ordering length

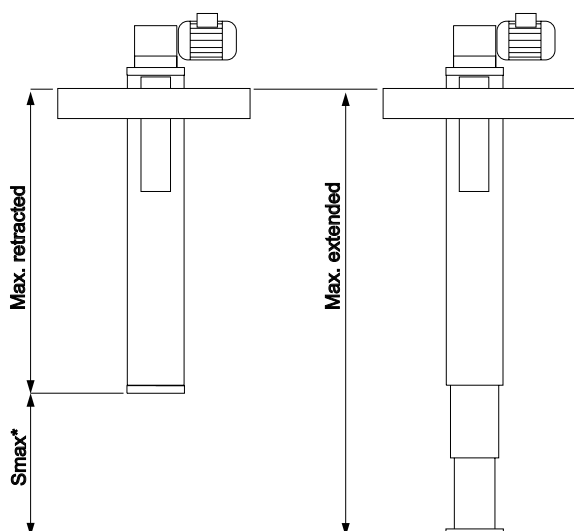

\* Smax = maximum stroke between the mechanical stops of the unit (theoretical stroke). Safe stroke is normally about 100 mm shorter (practical stroke).

## Movolift

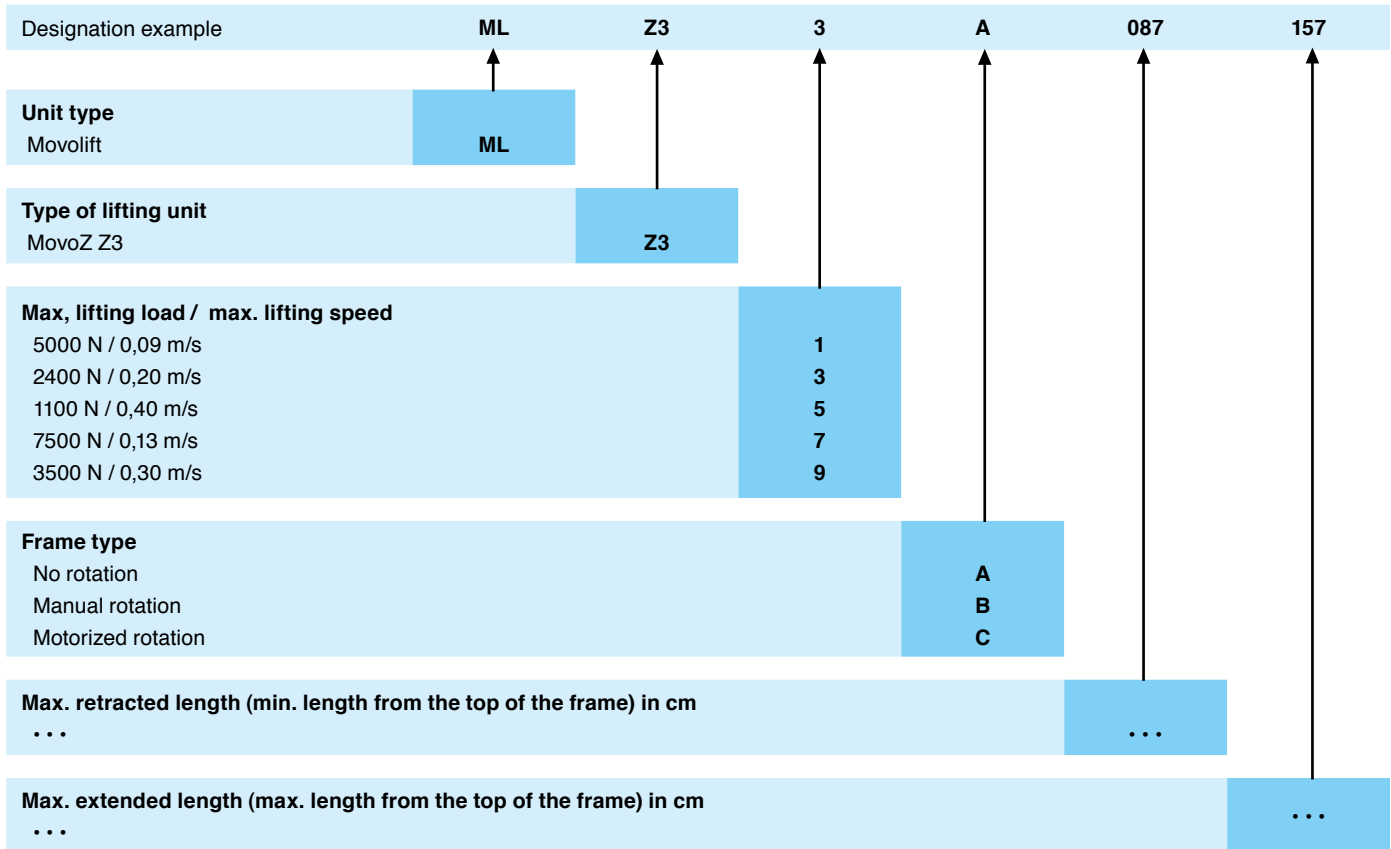

## EUROPE

### United Kingdom

Thomson  
Office 9, The Barns  
Caddsdawn Business Park  
Bideford  
Devon, EX39 3BT  
Phone: +44 (0) 1271 334 500  
E-mail: sales.uk@thomsonlinear.com

### Germany

Thomson  
Nürtinger Straße 70  
72649 Wolfschlügen  
Phone: +49 (0) 7022 504 0  
Fax: +49 (0) 7022 504 405  
E-mail: sales.germany@thomsonlinear.com

### France

Thomson  
Phone: +33 (0) 243 50 03 30  
Fax: +33 (0) 243 50 03 39  
E-mail: sales.france@thomsonlinear.com

### Italy

Thomson  
Largo Brughetti  
20030 Bovisio Masciago  
Phone: +39 0362 594260  
Fax: +39 0362 594263  
E-mail: sales.italy@thomsonlinear.com

### Spain

Thomson  
E-mail: sales.esm@thomsonlinear.com

### Sweden

Thomson  
Estridsväg 10  
29109 Kristianstad  
Phone: +46 (0) 44 24 67 00  
Fax: +46 (0) 44 24 40 85  
E-mail: sales.scandinavia@thomsonlinear.com

## SOUTH AMERICA

### Brasil

Thomson  
Av. Tamboré, 1077  
Barueri, SP – 06460-000  
Phone: +55 (11) 3616-0191  
Fax: +55 (11) 3611-1982  
E-mail: sales.brasil@thomsonlinear.com

## USA, CANADA and MEXICO

Thomson  
203A West Rock Road  
Radford, VA 24141, USA  
Phone: 1-540-633-3549  
Fax: 1-540-633-0294  
E-mail: thomson@thomsonlinear.com  
Literature: literature.thomsonlinear.com

## ASIA

### Asia Pacific

Thomson  
E-mail: sales.apac@thomsonlinear.com

### China

Thomson  
Rm 2205, Scitech Tower  
22 Jianguomen Wai Street  
Beijing 100004  
Phone: +86 400 6661 802  
Fax: +86 10 6515 0263  
E-mail: sales.china@thomsonlinear.com

### India

Thomson  
c/o Fluke Technologies Pvt. Ltd.  
#424, Deodhar Center,  
Marol Maroshi Road,  
Andheri – E, Mumbai – 400059 India  
Phone: +91 22 29207641  
E-mail: sales.india@thomsonlinear.com

### Japan

Thomson  
Minami-Kaneden 2-12-23, Suita  
Osaka 564-0044 Japan  
Phone: +81-6-6386-8001  
Fax: +81-6-6386-5022  
E-mail: csjapan@scgap.com

### Korea

Thomson  
F7 Ilsong Bldg, 157-37  
Samsung-dong, Kangnam-gu,  
Seoul, Korea (135-090)  
Phone: +82 2 6917 5049  
Fax: +82 2 528 1456  
E-mail: sales.korea@thomsonlinear.com

## **USA, CANADA and MEXICO**

Thomson  
203A West Rock Road  
Radford, VA 24141, USA  
Phone: 1-540-633-3549  
Fax: 1-540-633-0294  
E-mail: thomson@thomsonlinear.com  
Literature: literature.thomsonlinear.com

## **EUROPE**

### **United Kingdom**

Thomson  
Office 9, The Barns  
Caddsdow Business Park  
Bideford  
Devon, EX39 3BT  
Phone: +44 (0) 1271 334 500  
E-mail: sales.uk@thomsonlinear.com

### **Germany**

Thomson  
Nürtinger Straße 70  
72649 Wolfschlügen  
Phone: +49 (0) 7022 504 0  
Fax: +49 (0) 7022 504 405  
E-mail: sales.germany@thomsonlinear.com

### **France**

Thomson  
Phone: +33 (0) 243 50 03 30  
Fax: +33 (0) 243 50 03 39  
E-mail: sales.france@thomsonlinear.com

### **Italy**

Thomson  
Largo Brughetti  
20030 Bovisio Masciago  
Phone: +39 0362 594260  
Fax: +39 0362 594263  
E-mail: sales.italy@thomsonlinear.com

### **Spain**

Thomson  
E-mail: sales.esm@thomsonlinear.com

### **Sweden**

Thomson  
Estridsväg 10  
29109 Kristianstad  
Phone: +46 (0) 44 24 67 00  
Fax: +46 (0) 44 24 40 85  
E-mail: sales.scandinavia@thomsonlinear.com

## **ASIA**

### **Asia Pacific**

Thomson  
E-mail: sales.apac@thomsonlinear.com

### **China**

Thomson  
Rm 2205, Scitech Tower  
22 Jianguomen Wai Street  
Beijing 100004  
Phone: +86 400 6661 802  
Fax: +86 10 6515 0263  
E-mail: sales.china@thomsonlinear.com

### **India**

Thomson  
c/o Fluke Technologies Pvt. Ltd.  
#424, Deodhar Center,  
Marol Maroshi Road,  
Andheri – E, Mumbai – 400059 India  
Phone: +91 22 29207641  
E-mail: sales.india@thomsonlinear.com

### **Japan**

Thomson  
Minami-Kaneden 2-12-23, Suita  
Osaka 564-0044 Japan  
Phone: +81-6-6386-8001  
Fax: +81-6-6386-5022  
E-mail: csjapan@scgap.com

### **Korea**

Thomson  
F7 Ilsong Bldg, 157-37  
Samsung-dong, Kangnam-gu,  
Seoul, Korea (135-090)  
Phone: +82 2 6917 5049  
Fax: +82 2 528 1456  
E-mail: sales.korea@thomsonlinear.com

## **SOUTH AMERICA**

### **Brazil**

Thomson  
Av. Tamboré, 1077  
Barueri, SP – 06460-000  
Phone: +55 (11) 3616-0191  
Fax: +55 (11) 3611-1982  
E-mail: sales.brasil@thomsonlinear.com